

1/2-14 NPT
(FEM) OUTLET

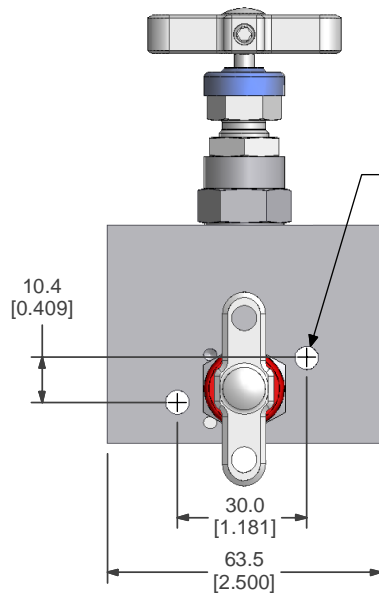

2 OFF Ø5.5 [0.216]
MTG. HOLES

10.4
[0.409]

30.0
[1.181]

63.5
[2.500]

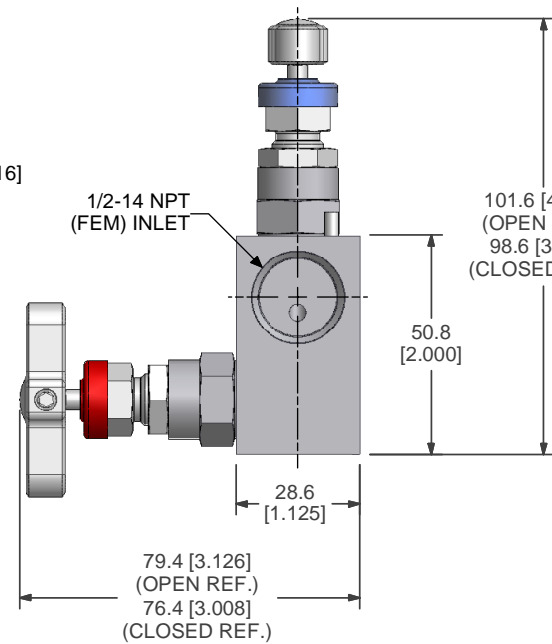

1/2-14 NPT
(FEM) INLET

101.6 [4.000]
(OPEN REF.)
98.6 [3.882]
(CLOSED REF.)

50.8
[2.000]

28.6
[1.125]

79.4 [3.126]
(OPEN REF.)
76.4 [3.008]
(CLOSED REF.)

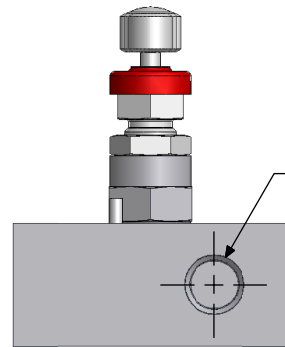
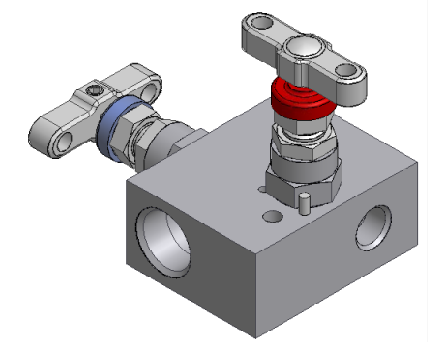

1/4-18 NPT
(FEM) VENT

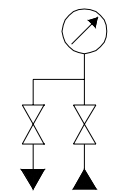

2 VALVE MANIFOLD REMOTE MTG
INLET : 1/2-14 NPT (FEM)
OUTLET : 1/2-14 NPT (FEM)
VENT : 1/4-18 NPT (FEM)
MATERIAL OF CONSTRUCTION :
SEE 'H-SERIES MATERIAL SPEC'.

FOR MATERIAL AND PROCESS SPECIFICATIONS REFER TO GENRIC PROCESS CONTROL SHEET ESSF N/A				ALL DIMENSIONS IN MM [INCHES] UNLESS OTHERWISE STATED			REMOVE ALL SHARP EDGES AND BURRS			 Instrumentation Parker Hannifin plc Instrumentation Products Division Riverside Road Barnstaple. Devon EX31 1NP
FOR PART MARKING DETAILS REFER TO PART MARKING SPECIFICATION ESSF N/A				DRAWING TITLE : 2 VALVE MANIFOLD REMOTE MTG PIPE TO PIPE 1/2-14 NPT (FEM) INLET/OUTLET 1/4-18 NPT VENT 6000 PSI RANGE CUSTOMER ASSEMBLY DRAWING			INCH (.00") ± .015" (.000") ± .005"	METRIC (.0)mm ± .3mm (.00mm) ± 0.1mm	ANGULAR ± 1/2° ± 30°	
THIS DRAWING CONTAINS INFORMATION THAT IS CONFIDENTIAL AND PROPRIETARY TO PARKER HANNIFIN PLC. THIS DRAWING IS FURNISHED ON THE UNDERSTANDING THAT THE DRAWING AND THE INFORMATION IT CONTAINS WILL NOT BE COPIED OR DISCLOSED TO OTHERS EXCEPT WITH THE WRITTEN CONSENT OF PARKER HANNIFIN. WILL NOT BE USED TO THE DETRIMENT OF PARKER HANNIFIN, AND WILL BE RETURNED UPON REQUEST BY PARKER HANNIFIN.				CHECKED BY : Approvals using electronic 'PDM WORKFLOW' (QSP05/25)			GENERAL M/C FINISH 63min CLA/ 1.6mm RA GEOMETRICAL TOL'S TO BS.308 PART 3. ALL THREAD TOLERANCES ARE TO BE IN ACCORDANCE WITH PARKER IPD ESST01.			
ISSUE NO.	1	DRAWN BY:	NICK HOLTON							
E.C.N NUMBER	CUST	DATE DRAWN	22/05/2002	DRAWING LOCATED IN PDM SYSTEM			DO NOT SCALE IF IN DOUBT ASK			
DATE	22/05/2002	SCALE	PROPORTIONAL							